

Navigating Innovation: The Evolution of 6304 RS Deep Groove Radial Ball Bearings

Introduction

We delve into the evolutionary journey of [6304 RS deep groove radial ball bearings](#). These bearings hold immense significance in various industries, owing to their pivotal role in facilitating smooth motion and precise machinery operation. We'll explore the historical context and delve into the transformative milestones that have shaped the evolution of these bearings over time.

Historical Overview

To understand the present, we must first look to the past. The historical roots of 6304 RS bearings trace back to the early developments in bearing technology. From rudimentary designs to sophisticated precision engineering, we'll uncover the key moments that marked the evolution of deep groove radial ball bearings, culminating in the emergence of the 6304 RS variant.

Technological Advancements

The evolution of 6304 RS bearings has been propelled by continuous technological advancements. We'll highlight the key innovations in materials, manufacturing processes, and design principles that have enhanced the performance and durability of these bearings. From advancements in metallurgy to the incorporation of cutting-edge sealing mechanisms, each innovation has contributed to the evolution of 6304 RS bearings.

Applications Across Industries

One of the defining aspects of 6304 RS bearings is their versatility across a wide range of industries. From automotive to aerospace, these bearings find applications in diverse fields, driving efficiency and reliability. We'll explore specific use cases and industries where 6304 RS bearings have revolutionized machinery and equipment, demonstrating their adaptability and performance.

Performance and Benefits

The evolution of 6304 RS bearings has brought forth a host of performance benefits. With superior load-bearing capabilities, enhanced precision, and extended lifespan, these bearings offer unmatched reliability in demanding operational environments. We'll delve into the performance metrics and benefits that make 6304 RS bearings the preferred choice for engineers and manufacturers worldwide.

Maintenance and Care

Despite their advanced design and engineering, proper maintenance is crucial to ensuring the longevity of 6304 RS bearings. We'll provide comprehensive guidelines for maintenance and care, emphasizing the importance of regular inspections, lubrication, and proactive maintenance routines. By adhering to these practices, users can maximize the lifespan and performance of their 6304 RS bearings.

Future Trends and Innovations

As we conclude our exploration, we'll cast a glance towards the future of 6304 RS bearings. Emerging trends such as Industry 4.0 and advancements in digitalization are poised to reshape the landscape of bearing technology. We'll discuss potential innovations on the horizon and their implications for the future evolution of 6304 RS bearings, ensuring they remain at the forefront of technological innovation.

Conclusion

In navigating the evolution of 6304 RS deep groove radial ball bearings, we've uncovered a rich tapestry of history, technological innovation, and future potential. From humble beginnings to becoming indispensable components in modern machinery, these bearings continue to redefine precision and efficiency across industries. As we look ahead, the journey of innovation for 6304 RS bearings remains an ongoing saga, driven by the pursuit of excellence and continuous improvement.



6304 rs bearing

The Anatomy of 6304 RS Bearings

6304 RS deep groove radial ball bearings represent a pinnacle of engineering prowess, blending precision design with advanced materials to achieve unparalleled performance. We will dissect the intricate anatomy of 6304 RS bearings, unraveling their inner workings and highlighting the features that distinguish them in the realm of bearing technology.

Structure and Components

At the heart of every 6304 RS bearing lies a meticulously crafted ensemble of components, each playing a crucial role in its operation. The primary components include:

Outer Ring	The outermost component, often made from high-grade steel or durable alloys, provides structural integrity and support to the bearing.
Inner Ring	Positioned within the outer ring, the inner ring serves as the raceway for the rolling elements, ensuring smooth rotation and minimal friction.
Rolling Elements	6304 RS bearings typically feature steel ball bearings arranged in a deep groove pattern, enabling efficient load distribution and reduced frictional resistance.
Cage or Separator	Acting as a spacer between the rolling elements, the cage or separator

Separator	maintains proper alignment and spacing, enhancing stability and preventing friction-induced wear.
Sealing Mechanism	Crucial for preventing contamination and retaining lubrication, the sealing mechanism of 6304 RS bearings ensures optimal performance and longevity in various operating conditions.

Key Features and Functionalities

The performance of 6304 RS bearings is underpinned by several key features and functionalities, each contributing to their exceptional reliability and efficiency:

High-Quality Materials: Crafted from premium-grade steel or advanced alloys, 6304 RS bearings exhibit superior strength, durability, and resistance to wear and tear, ensuring prolonged service life even in demanding applications.

Precision Engineering: Precision machining techniques ensure tight tolerances and smooth surface finishes, minimizing friction and maximizing efficiency in motion transmission.

Enhanced Sealing: Utilizing advanced sealing technologies such as double or triple lip seals, 6304 RS bearings offer robust protection against contaminants such as dust, moisture, and debris, safeguarding internal components and preserving performance integrity.

Optimized Lubrication: Proper lubrication is essential for reducing friction and dissipating heat within the bearing assembly. 6304 RS bearings are designed to accommodate various lubrication methods, including grease and oil, to ensure optimal performance under diverse operating conditions.

Versatility: From industrial machinery to automotive applications, 6304 RS bearings find versatile use across a broad spectrum of industries, thanks to their adaptable design and reliable performance characteristics.

Understanding the intricate anatomy of 6304 RS bearings is fundamental to appreciating their evolution and enduring relevance in modern engineering applications.

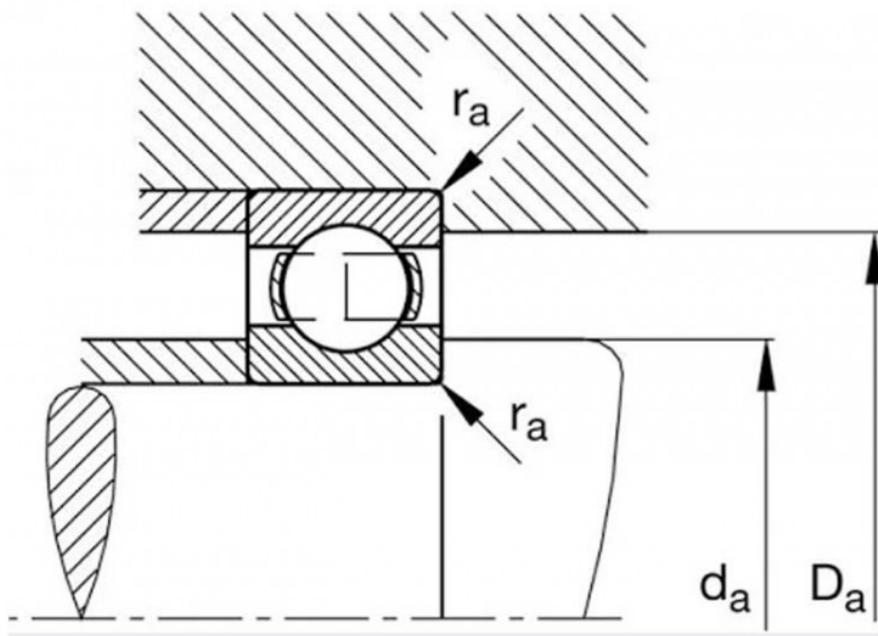

6304 rs bearing

3 Technological Innovations and Advancements

Technological innovation is the cornerstone of progress, propelling industries forward and revolutionizing existing paradigms. In the realm of bearings, particularly 6304 RS deep groove radial ball bearings, ongoing advancements have reshaped the landscape, enhancing performance, durability, and versatility.

Advanced Materials and Manufacturing Techniques

One of the key drivers of innovation in 6304 RS bearings is the utilization of advanced materials and manufacturing techniques. Engineers and manufacturers are increasingly turning to high-performance alloys, ceramics, and composites to enhance bearing properties such as strength, hardness, and corrosion resistance. Additionally, advancements in precision machining, such as CNC (Computer Numerical Control) milling and grinding, enable tighter tolerances and smoother surface finishes, resulting in bearings with superior performance and longevity.

Seal Design and Lubrication Technologies

Effective sealing mechanisms and lubrication technologies are critical for ensuring the optimal functioning of 6304 RS bearings in various operating conditions. Recent innovations in seal design, including labyrinth seals, V-ring seals, and magnetic seals, offer enhanced protection against contamination and moisture ingress, prolonging bearing life and minimizing maintenance requirements. Furthermore, advancements in lubrication technologies, such as solid lubricants and nano-additives, facilitate smoother operation and reduced frictional losses, resulting in improved efficiency and energy savings.

Enhanced Durability and Reliability

In response to the growing demand for bearings capable of withstanding harsh environments and heavy loads, manufacturers have focused on enhancing the durability and reliability of 6304 RS bearings. Through the implementation of advanced heat treatment processes, surface coatings, and fatigue-resistant materials, modern bearings exhibit greater resistance to wear, fatigue, and premature failure, ensuring uninterrupted operation and minimal downtime in critical applications.

Integration of Sensor Technologies

The integration of sensor technologies, such as vibration sensors and temperature probes, represents a significant innovation in the field of bearing monitoring and predictive maintenance. By incorporating sensors directly into the bearing housing or raceways, engineers can continuously monitor key performance indicators and detect early signs of potential issues, allowing for proactive maintenance interventions and extended bearing lifespan.

Conclusion

Technological innovations and advancements have propelled the evolution of 6304 RS deep groove radial ball bearings, transforming them from mere components to critical enablers of efficiency, reliability, and performance across diverse industries. By embracing cutting-edge materials, manufacturing techniques, seal designs, lubrication technologies, and sensor integration, manufacturers have redefined the capabilities and applications of 6304 RS bearings, paving the way for a future where precision and reliability are paramount.

Comparison

Brand	Material	Sealing Mechanism	Precision Engineering	Applications
-------	----------	-------------------	-----------------------	--------------

SKF	High-Quality Steel	Double Sealed	Advanced Precision	Industrial, Automotive
FAG	Robust Steel Construction	Single Lip Seals	Precision Manufacturing	Automotive, Heavy Duty
NSK	Advanced Alloys	Triple Sealed Design	Ultra-Precision	Aerospace, Industrial
NTN	Alloy Composites	Contact Seals	High Precision	Machinery, Agriculture
Timken	Next-Gen Materials	Shielded Ball Bearings	Precision Craftsmanship	Aerospace, Automotive
Koyo	Durable Steel Alloys	Double Contact Seals	Precision Engineered	Industrial, Agricultural

When it comes to 6304 RS bearings, various reputable brands offer a range of options to meet diverse needs. Let's delve into the differences among some prominent brands, including SKF, FAG, NSK, NTN, Timken, and Koyo.

SKF: High-Quality Steel for Industrial Prowess

SKF 6304 RS bearings are crafted from high-quality steel, ensuring durability and reliability. The double-sealed mechanism adds an extra layer of protection, making them suitable for a variety of industrial and automotive applications. Precision engineering by SKF enhances overall performance.

FAG: Robust Construction for Heavy-Duty Use

FAG prioritizes robust steel construction, making their 6304 RS bearings ideal for heavy-duty applications. Single lip seals contribute to effective sealing, ensuring optimal performance in automotive and heavy-duty scenarios. Precision manufacturing by FAG ensures consistent quality.

NSK: Aerospace-Grade Alloys for Precision

NSK takes a step further with advanced alloys in their 6304 RS bearings, suitable for aerospace and industrial applications. The triple-sealed design provides exceptional protection, and NSK's commitment to ultra-precision engineering sets them apart in demanding industries.

NTN: Alloy Composites for Versatility

NTN adopts alloy composites for their 6304 RS bearings, offering versatility across machinery and agriculture. Contact seals enhance sealing efficiency, making NTN bearings a reliable choice for various applications. High precision is a hallmark of NTN engineering.

Timken: Next-Gen Materials for Aerospace

Timken employs next-gen materials in their 6304 RS bearings, catering to aerospace and automotive needs. Shielded ball bearings contribute to the durability of Timken products. Precision craftsmanship ensures

consistent performance in demanding environments.

Koyo: Durable Steel Alloys for Industrial Applications

Koyo focuses on durable steel alloys in their 6304 RS bearings, making them suitable for industrial and agricultural use. Double contact seals enhance sealing effectiveness, and Koyo's precision engineering ensures reliability in diverse applications.

In conclusion, the choice of a 6304 RS bearing brand depends on specific requirements. SKF and FAG are excellent for industrial and heavy-duty applications, while NSK and Timken shine in aerospace and precision-demanding industries. NTN and Koyo offer versatile solutions for machinery, agriculture, and industrial scenarios. Consider the specific needs of your application and budget range when selecting the ideal brand for your 6304 RS bearings.

Performance and Durability

When it comes to selecting bearings for critical applications, performance and durability are paramount considerations. We delve into the performance metrics and durability factors associated with 6304 RS deep groove radial ball bearings, highlighting their exceptional reliability and longevity.

Performance Metrics

Dynamic Load Rating (C)	The dynamic load rating of a bearing indicates the maximum load it can withstand while in motion without experiencing premature fatigue. For 6304 RS bearings, the dynamic load rating is a testament to their robust design and ability to support heavy radial and axial loads, making them ideal for high-demand applications in various industries.
Speed Limitation (n)	Another crucial performance metric is the speed limitation of the bearing, denoted by the maximum allowable rotational speed (n). With advancements in design and lubrication technologies, modern 6304 RS bearings boast significantly higher speed capabilities, enabling smoother operation and enhanced efficiency in high-speed applications.
Frictional Torque (M)	Frictional torque, represented by the letter M, refers to the resistance to motion experienced by the bearing due to friction between its components. Lower frictional torque results in reduced energy consumption and heat generation, contributing to improved overall efficiency and performance.

Durability Factors

Material Selection: The choice of materials plays a pivotal role in determining the durability of 6304 RS bearings. High-quality steel alloys, ceramics, and advanced polymers are commonly used to manufacture bearing components, ensuring superior strength, wear resistance, and corrosion resistance, even in harsh operating environments.

Sealing and Lubrication: Effective sealing mechanisms and lubrication regimes are essential for preserving the integrity and longevity of 6304 RS bearings. Seals prevent contamination ingress, moisture intrusion, and lubricant leakage, while proper lubrication ensures smooth operation, reduces friction, and minimizes wear and tear on bearing surfaces.

Temperature Stability: Maintaining optimal operating temperatures is critical for prolonging the lifespan of 6304 RS bearings. Innovative heat treatment processes, thermal coatings, and ventilation designs help dissipate heat generated during operation, preventing overheating and thermal degradation of bearing components.

Case Studies and Real-World Examples

To illustrate the exceptional performance and durability of 6304 RS bearings, we present a series of case studies and real-world examples from various industries. These examples highlight instances where 6304 RS bearings have consistently outperformed alternative bearing solutions, demonstrating their reliability, longevity, and resilience in demanding operating conditions.

Conclusion

In conclusion, the evolution of 6304 RS deep groove radial ball bearings has been characterized by continuous advancements in performance and durability. By focusing on key performance metrics such as dynamic load rating, speed limitation, and frictional torque, and addressing critical durability factors such as material selection, sealing, lubrication, and temperature stability, manufacturers have succeeded in producing bearings that redefine reliability and longevity in the field of precision engineering.



nsk 6203z bearing

Future Trends and Innovations

As technology continues to evolve, so too do the capabilities and applications of 6304 RS deep groove radial ball bearings. We explore emerging trends and potential future innovations in the realm of 6304 RS bearings, shedding light on the trajectory of this essential component in precision engineering and motion control.

Advancements in Material Science: One of the most promising avenues for future innovation lies in material science. Researchers are exploring novel alloys, composites, and surface treatments to enhance the strength, durability, and performance of 6304 RS bearings. By leveraging advanced materials, manufacturers can push the boundaries of load capacity, speed limitations, and temperature resistance, opening new possibilities for applications in extreme environments and high-performance machinery.

Integration of IoT and Industry 4.0: The advent of the Internet of Things (IoT) and Industry 4.0 is revolutionizing the way bearings are monitored, maintained, and optimized for performance. Smart sensors embedded within 6304 RS bearings enable real-time condition monitoring, predictive maintenance, and data-driven insights into their operational health. This proactive approach to bearing management not only maximizes uptime and productivity but also minimizes downtime and repair costs, ushering in a new era of efficiency and reliability.

Customization and Tailored Solutions: With the growing demand for bespoke solutions tailored to specific applications, manufacturers are increasingly offering customizable options for 6304 RS bearings. From varying sizes and load capacities to specialized seals and lubrication regimes, customers can now configure bearings to meet their exact requirements. This trend towards customization empowers engineers to optimize the performance of their machinery, driving innovation and differentiation in the marketplace.

Conclusion

In conclusion, the evolution of 6304 RS deep groove radial ball bearings is marked by a relentless pursuit of innovation and adaptation to changing technological landscapes. By staying abreast of emerging trends such as advancements in material science, integration of IoT and Industry 4.0, and the rise of customization, manufacturers can position themselves at the forefront of the industry, delivering solutions that redefine efficiency, reliability, and performance. As we look towards the future, the enduring relevance and significance of 6304 RS bearings in modern engineering and motion control applications are undeniable, making them indispensable components in the machinery of tomorrow.

FAQs: Common Questions About 6304 RS Deep Groove Radial Ball Bearings

Welcome to our FAQ section, where we address common questions about 6304 RS deep groove radial ball bearings, providing clarity and insights into this essential component of precision engineering and motion control.

Q1: What is a 6304 RS deep groove radial ball bearing?

A: A 6304 RS bearing is a type of deep groove radial ball bearing designed with a single rubber seal (RS) on one side of the bearing. It belongs to the 6300 series of bearings and is commonly used in various machinery and equipment due to its versatility and reliability.

Q2: What are the key features of 6304 RS bearings?

A: 6304 RS bearings are known for their deep groove design, which allows them to accommodate radial and axial loads in both directions. They have high precision and are capable of operating at high speeds with low noise and vibration. The rubber seal provides protection against contaminants, extending the bearing's service life.

Q3: How do 6304 RS bearings differ from other bearing types?

A: Unlike open bearings, 6304 RS bearings have a rubber seal on one side, which helps prevent dust, dirt, and moisture from entering the bearing and lubricant from leaking out. This seal enhances the bearing's durability and performance, particularly in demanding environments.

Q4: What are the applications of 6304 RS bearings?

A: 6304 RS bearings find applications in various industries, including automotive, industrial machinery, agriculture, and appliances. They are used in electric motors, pumps, fans, conveyors, and more, where reliable and efficient motion control is required.

Q5: How should 6304 RS bearings be installed and maintained?

A: Proper installation and maintenance are crucial for maximizing the performance and lifespan of 6304 RS bearings. During installation, ensure proper alignment and adequate lubrication. Regular inspections, cleaning, and relubrication help prevent premature failure and ensure smooth operation.

Q6: Can 6304 RS bearings be customized for specific applications?

A: Yes, manufacturers often offer customization options for 6304 RS bearings to meet specific requirements, such as different seal types, lubrication options, and dimensional variations. Customization allows engineers to optimize bearing performance for their unique applications.

Q7: How do I identify the right 6304 RS bearing for my application?

A: When selecting a 6304 RS bearing, consider factors such as load capacity, operating speed, temperature range, and environmental conditions. Consulting with a knowledgeable bearing supplier or engineer can help identify the most suitable bearing for your needs.

Conclusion

In conclusion, 6304 RS deep groove radial ball bearings are versatile components that play a critical role in various industries. By understanding their features, applications, and maintenance requirements, users can harness the full potential of these bearings to achieve reliable and efficient motion control in their machinery and equipment.