

# Elevating Operations: Optimizing Machinery with 6014 Deep Groove Ball Bearing

## 1 Introduction

In the realm of industrial machinery, the significance of [6014 deep groove ball bearings](#) cannot be overstated. These bearings, renowned for their robustness and reliability, play a pivotal role in optimizing machinery operations. As machinery continues to evolve in complexity and demand, the need for efficient components like the 6014 bearing becomes increasingly paramount.

Within the scope of industrial settings, machinery optimization stands as a cornerstone for achieving peak performance and productivity. From manufacturing plants to automotive assembly lines, the efficiency of machinery directly influences overall output and profitability. Amidst this backdrop, the choice of bearings emerges as a critical decision, impacting everything from operational reliability to maintenance costs.

Selecting the right bearings is imperative for ensuring machinery efficiency. As machinery operates under varying conditions and loads, the performance of bearings can significantly affect overall functionality. Hence, understanding the attributes and applications of bearings, particularly the 6014 deep groove ball bearing, is essential for elevating operations and maximizing productivity.

In mechanical engineering applications, selecting the right brand of bearings is crucial for ensuring optimal performance and reliability.

Brand	Features	Benefits	Drawbacks
SKF	High-quality steel construction	Excellent load-carrying capacity	Relatively higher cost
NSK	Precision engineering for smooth operation	Long service life	Limited availability in some regions
FAG	Advanced sealing technology for contamination resistance	Suitable for harsh environments	Premium pricing
NTN	Wide range of applications	Cost-effective option	May require frequent maintenance
Timken	Superior durability and reliability	Trusted brand in the industry	Higher initial investment

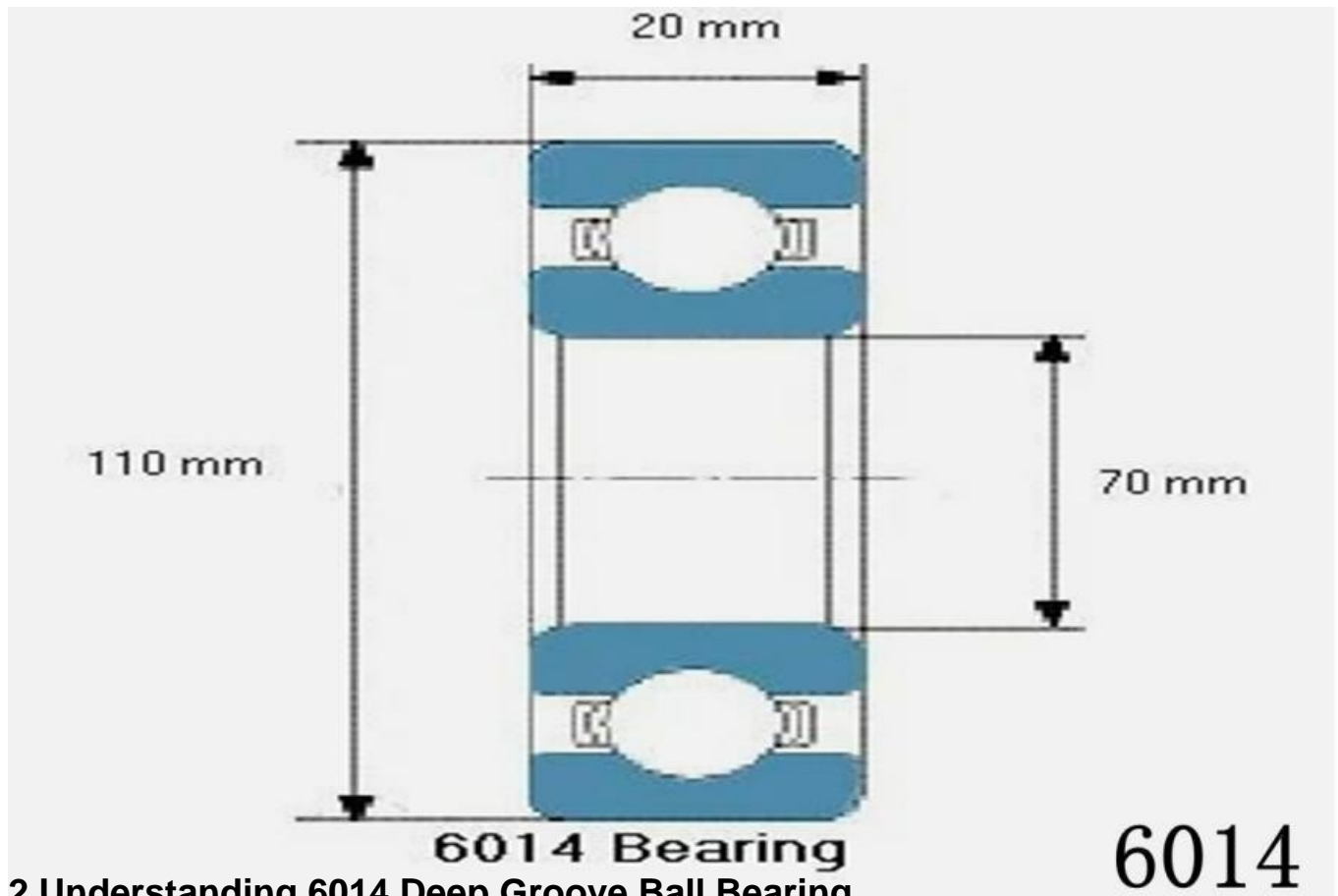

## 2 Understanding 6014 Deep Groove Ball Bearing

### Structural Components and Design Specifications

The 6014 deep groove ball bearing is engineered with precision to withstand substantial radial and axial loads. Its design comprises an inner ring, outer ring, cage, and a complement of steel balls. These components work synergistically to facilitate smooth rotation while maintaining stability under varying loads and speeds. The precision engineering ensures minimal friction and heat generation, enhancing operational efficiency and longevity.

### Load-Bearing Capacity and Performance Characteristics

One of the standout features of the 6014 bearing is its impressive load-bearing capacity. Designed to accommodate both radial and axial loads, it excels in applications where heavy-duty performance is required. The bearing's ability to distribute loads evenly across its components minimizes stress concentrations, reducing the risk of premature wear and failure. Additionally, the 6014 bearing demonstrates excellent rotational accuracy, making it suitable for high-speed machinery applications.

## Lubrication Requirements and Maintenance Guidelines

Proper lubrication is paramount to ensure the optimal performance and longevity of 6014 deep groove ball bearings. The selection of appropriate lubricants and the establishment of regular maintenance schedules are crucial aspects of bearing care. By minimizing friction and reducing wear, effective lubrication enhances the bearing's operational lifespan and reliability. Moreover, routine inspections and lubricant replenishment help detect potential issues early, mitigating the risk of costly downtime and repairs.

## Applications Across Various Industries and Machinery Types

The versatility of the 6014 deep groove ball bearing renders it indispensable across a wide spectrum of industries and machinery types. From heavy machinery in construction to precision equipment in the aerospace sector, these bearings find application in diverse environments. Their robust construction and reliable performance make them ideal for conveyor systems, pumps, motors, and other critical components of industrial machinery. The 6014 bearing's adaptability underscores its significance in enhancing operational efficiency and reliability across various industrial sectors.

## 3 Optimizing Machinery Performance with 6014 Bearings

In the realm of industrial machinery optimization, the selection of suitable components is paramount to achieving peak performance and efficiency. Among these components, 6014 bearings stand out as indispensable elements that play a pivotal role in enhancing machinery functionality and reliability.

Integration of 6014 Bearings for Enhanced Machinery Functionality	The integration of 6014 deep groove ball bearings marks a significant stride towards enhancing machinery functionality. By leveraging the robustness and reliability of these bearings, industrial equipment can operate with greater precision and efficiency. Whether utilized in conveyor systems, gearboxes, or machine tools, the 6014 bearing's ability to withstand heavy loads and high speeds ensures smooth operation under demanding conditions. The seamless integration of 6014 bearings into machinery designs underscores their pivotal role in optimizing performance.
---	--

<p>Improving Operational Efficiency and Reducing Downtime</p>	<p>One of the primary objectives of incorporating 6014 bearings is to improve operational efficiency and minimize downtime. These bearings excel in maintaining stable performance over prolonged periods, thereby reducing the frequency of maintenance interventions and repairs. With fewer instances of machinery downtime, production processes can operate uninterrupted, leading to enhanced productivity and profitability. The reliability of 6014 bearings translates into tangible gains in operational efficiency, enabling businesses to meet production targets with confidence.</p>
<p>Case Studies Showcasing Successful Implementation</p>	<p>Numerous case studies attest to the efficacy of integrating 6014 bearings in optimizing machinery performance across diverse industrial sectors. For instance, in the manufacturing industry, a leading automotive plant reported a significant reduction in downtime after upgrading to 6014 bearings in their assembly line robots. Similarly, a mining operation achieved notable improvements in equipment reliability and maintenance costs by transitioning to 6014 bearings in their heavy-duty machinery. These real-world examples underscore the transformative impact of 6014 bearings on machinery optimization and operational outcomes.</p>
<p>Cost-Effectiveness and Long-Term Benefits of Utilizing 6014 Bearings</p>	<p>While the initial investment in 6014 bearings may seem substantial, the long-term benefits far outweigh the costs. The durability and longevity of these bearings translate into lower maintenance expenses and reduced replacement frequency. Moreover, the enhanced operational efficiency facilitated by 6014 bearings leads to increased production output and revenue generation. When considering the total cost of ownership, including maintenance, downtime, and productivity gains, the utilization of 6014 bearings emerges as a cost-effective investment with substantial returns over the equipment's lifecycle.</p>



# 6014

## 4 Challenges and Solutions

Despite their reliability and versatility, 6014 bearings may encounter various challenges during operation. One common issue is contamination, where foreign particles infiltrate the bearing, leading to premature wear and failure. Additionally, improper installation, inadequate lubrication, and overloading can exacerbate bearing problems, compromising machinery performance and safety.

<p>Strategies to Address Installation and Compatibility Issues</p>	<p>To mitigate installation and compatibility challenges, meticulous attention to detail is paramount. Proper alignment and mounting procedures ensure that 6014 bearings are installed correctly, minimizing the risk of misalignment-induced failure. Moreover, compatibility assessments with surrounding components and lubrication systems help optimize bearing performance and longevity. By adhering to manufacturer guidelines and industry best practices, engineers can preemptively address installation and compatibility issues, enhancing overall machinery reliability.</p>
<p>Maintenance Practices to Prolong Bearing Lifespan and Performance</p>	<p>Regular maintenance is essential for prolonging the lifespan and performance of 6014 bearings. Scheduled inspections</p>

	<p>enable early detection of potential issues, allowing for timely corrective action to prevent catastrophic failures. Lubrication management plays a crucial role in maintaining optimal bearing performance, as inadequate lubrication can lead to increased friction and heat generation. Additionally, implementing condition monitoring technologies, such as vibration analysis and thermal imaging, enhances predictive maintenance capabilities, enabling proactive interventions to mitigate bearing-related issues.</p>
<p>Innovations in Bearing Technology to Overcome Challenges</p>	<p>In response to evolving industry demands, bearing manufacturers continually innovate to overcome challenges associated with 6014 bearings. Advanced materials and coatings enhance bearing durability and resistance to contamination, extending service life in harsh operating environments. Furthermore, integrated sensor technologies provide real-time monitoring of bearing health, facilitating predictive maintenance strategies and minimizing unplanned downtime. By harnessing these innovations, businesses can optimize machinery reliability and performance, achieving greater operational efficiency and cost savings.</p>

## 5 Future Outlook and Considerations

### Emerging Trends in Bearing Technology and Industrial Automation

The future of bearing technology is intertwined with the broader landscape of industrial automation. As industries embrace digitalization and Industry 4.0 initiatives, bearings are evolving to meet the demands of interconnected and intelligent machinery systems. Emerging trends include the integration of smart sensors for real-time monitoring, the adoption of predictive maintenance algorithms for proactive intervention, and the development of self-lubricating and self-aligning bearing solutions. These advancements herald a new era of predictive and autonomous maintenance practices, enabling businesses to optimize operational efficiency and minimize downtime.

## **Potential Advancements in 6014 Bearing Design and Performance**

In the realm of 6014 bearing design, continuous innovation is driving improvements in performance, reliability, and efficiency. Future advancements may focus on enhancing load-carrying capacity, reducing frictional losses, and extending service intervals. Novel materials and manufacturing techniques, such as additive manufacturing and nanotechnology, hold promise for creating bearings with superior mechanical properties and enhanced wear resistance. Furthermore, the integration of digital twin technology enables virtual prototyping and optimization of bearing designs, facilitating rapid iteration and customization to meet specific application requirements.

## **Implications for the Future of Machinery Optimization**

The evolution of bearing technology, particularly the advancements in 6014 bearings, has far-reaching implications for the future of machinery optimization. By leveraging state-of-the-art bearings, businesses can achieve unprecedented levels of reliability, efficiency, and performance across their operations. Machinery optimization strategies will increasingly rely on data-driven insights and predictive analytics to anticipate maintenance needs and optimize equipment utilization. Moreover, the seamless integration of advanced bearings into machinery designs enables the development of agile and adaptable manufacturing systems capable of responding rapidly to changing market dynamics and customer demands.

## **Recommendations for Stakeholders in Adopting 6014 Bearing Solutions**

As stakeholders consider adopting 6014 bearing solutions, several recommendations can guide their decision-making process. Firstly, investing in comprehensive training programs ensures that personnel possess the requisite knowledge and skills to install, maintain, and troubleshoot bearings effectively. Secondly, fostering partnerships with reputable bearing suppliers facilitates access to cutting-edge technologies and support services, enhancing reliability and uptime. Lastly, embracing a proactive approach to maintenance, leveraging predictive analytics and condition monitoring tools, enables organizations to maximize the value proposition of 6014 bearings, driving sustained operational excellence and competitive advantage.

In conclusion, the future of machinery optimization is inexorably linked to the advancement of bearing technology, with 6014 bearings poised to play a pivotal role in shaping the industrial landscape. By embracing innovation and adopting best practices, stakeholders can harness the full potential of 6014 bearings to achieve unparalleled levels of performance and efficiency in their operations.



6014

## 6 Conclusion

In conclusion, the significance of 6014 bearings in machinery optimization cannot be overstated.

6014 bearings serve as the cornerstone of machinery optimization efforts, providing robust support for heavy loads and high speeds while maintaining precision and stability. Their versatility and durability make them indispensable components in various machinery types, from conveyor systems to automotive assembly lines.

Despite their numerous benefits, 6014 bearings are not without challenges. Issues such as contamination, improper installation, and maintenance requirements can pose obstacles to optimal performance. However, by adopting proactive maintenance practices and leveraging innovative technologies, these challenges can be mitigated effectively.

In summary, the key benefits of 6014 bearings include improved operational efficiency, reduced downtime, and enhanced reliability. By optimizing machinery with these advanced bearings, industries can realize significant cost savings, increased productivity, and a competitive edge in the market.



As we look towards the future, it is imperative for industries to embrace advanced bearing solutions such as the 6014 bearing. By investing in cutting-edge technologies, comprehensive training programs, and strategic partnerships with reliable suppliers, industries can unlock the full potential of 6014 bearings and drive sustained growth and success.

In light of the transformative impact these bearings offer, we call upon industries to take proactive steps towards embracing advanced bearing solutions for improved operations and a brighter future. Together, let us embark on a journey towards enhanced efficiency, reliability, and competitiveness through the adoption of 6014 bearings in machinery optimization.

## **7 FAQs: Common Questions About 6014 Bearing**

As the utilization of 6014 bearings becomes increasingly prevalent across various industries, it's natural for questions to arise regarding their features, applications, and maintenance. Below, we address some of the most frequently asked questions about 6014 bearings:

### **Q1: What is a 6014 bearing, and how does it differ from other bearings?**

A: A 6014 bearing is a type of deep groove ball bearing characterized by its ability to accommodate both radial and axial loads. It features an inner ring, outer ring, cage, and a complement of steel balls, designed to facilitate smooth rotation and distribute loads evenly. Compared to other bearings, such as roller bearings, 6014 bearings offer lower friction and higher rotational speeds, making them suitable for a wide range of applications.

### **Q2: What are the key benefits of using 6014 bearings in machinery?**

A: The utilization of 6014 bearings offers several key benefits, including:

1. High load-carrying capacity: 6014 bearings can withstand substantial radial and axial loads, making them ideal for heavy-duty applications.
2. Smooth operation: These bearings minimize friction and heat generation, ensuring smooth rotation and efficient performance.

3. Versatility: 6014 bearings find applications across various industries and machinery types, from automotive to manufacturing.

4. Reliability: With proper maintenance, 6014 bearings demonstrate long service life and consistent performance, contributing to reduced downtime and maintenance costs.

**Q3: What are some common challenges associated with 6014 bearings, and how can they be addressed?**

A: Despite their reliability, 6014 bearings may face challenges such as contamination, improper installation, and inadequate lubrication. To address these issues, it's essential to:

- Implement regular maintenance practices, including lubrication replenishment and inspections.
- Ensure proper installation and alignment of bearings to prevent misalignment-induced failures.
- Minimize contamination by sealing bearings effectively and implementing clean operating environments.

**Q4: How can I determine if a 6014 bearing is the right choice for my machinery?**

A: The selection of bearings depends on various factors, including load requirements, operating conditions, and application-specific considerations. Consulting with bearing experts and conducting thorough assessments of machinery requirements can help determine whether a 6014 bearing is the optimal choice for your application.

**Q5: Are there any advancements or innovations in 6014 bearing technology worth noting?**

A: Yes, bearing manufacturers continually innovate to enhance the performance and reliability of 6014 bearings. Some notable advancements include:

- Integration of smart sensors for real-time monitoring of bearing health.
- Development of self-lubricating and self-aligning bearing solutions.
- Utilization of advanced materials and coatings for improved durability and wear resistance.

By addressing these frequently asked questions, we aim to provide a comprehensive understanding of 6014 bearings and their role in optimizing machinery performance.